

Uninterruptible power supply - STEP-UPS/24DC/24DC/3/46WH - 1081430

Please be informed that the data shown in this PDF Document is generated from our Online Catalog. Please find the complete data in the user's documentation. Our General Terms of Use for Downloads are valid (<http://phoenixcontact.com/download>)



Uninterruptible power supply with integrated battery module. The STEP-BAT/LI-ION/18.5DC/46WH battery module can be re-ordered separately.

Product Description

UPS modules with integrated energy storage are particularly space saving: UPS module and energy storage are combined in one housing. It's just a case of connecting a power supply upstream.

Your advantages

- ✓ Stable supply of sensitive loads, thanks to the regulated output voltage
- ✓ Safety ensured, thanks to the integrated protective circuit and energy storage temperature monitoring
- ✓ Quick and easy installation, thanks to integrated energy storage
- ✓ Battery operation can be stopped via remote contact
- ✓ Flexible assembly – can be snapped onto the DIN rail or screwed onto a level surface



Key Commercial Data

Packing unit	1 pc
GTIN	 4 055626 807850
GTIN	4055626807850
Weight per Piece (excluding packing)	500.000 g
Weight per piece (including packing)	510.000 g
Custom tariff number	85371091
Country of origin	Germany

Technical data

Dimensions

Width	108 mm
Height	90 mm
Depth	71 mm

Uninterruptible power supply - STEP-UPS/24DC/24DC/3/46WH - 1081430

Technical data

Ambient conditions

Degree of protection	IP20
Ambient temperature (operation)	0 °C ... 40 °C
Ambient temperature (storage/transport)	-20 °C ... 45 °C
Max. permissible relative humidity (operation)	≤ 95 % (at 25 °C, non-condensing)
Climatic class	3K3 (in acc. with EN 60721)
Degree of pollution	2

Input data

Input voltage	24 V DC
Nominal input voltage	24 V DC
Input voltage range	22.5 V DC ... 29.5 V DC
Current consumption (charging process)	< 0.5 A (Charging (I _{Charge} = max, I _{Out} = 0))
Current consumption (maximum)	4.7 A
Current consumption (idle)	< 30 mA
Fixed backup threshold	< 22.5 V
Variable connect threshold	1 V / 1 s
Input fuse, integrated	7 A (slow-blow, internal)

Output data (24 V DC mains operation)

Nominal output voltage	24 V DC
Output voltage range (depends on the input voltage)	22.5 V DC ... 29.5 V DC (U _{Out} = U _{In} - 0.3 V DC)
Nominal output current (I _N)	3 A (0 °C ... 40 °C)

Output data (24 V DC battery operation)

Nominal output voltage	24 V DC
Output voltage range (depends on the input voltage)	23 V DC ... 26.5 V DC (U _{Out} = U _{In (t-1)})
Nominal output current (I _N)	3 A (0 °C ... 40 °C)

General output data

Efficiency	> 98 % (Mains operation, with charged energy storage)
------------	---

General

IQ technology	no
Net weight	0.51 kg
Memory medium	Lithium-ion
Protection class	III
MTBF (IEC 61709, SN 29500)	> 1401000 h (40 °C)
Mounting position	horizontal DIN rail NS 35, EN 60715
Assembly instructions	alignable: horizontally 0 mm, vertically 50 mm

Connection data, input

Connection method	Screw connection
Conductor cross section solid min.	0.2 mm ²

Uninterruptible power supply - STEP-UPS/24DC/24DC/3/46WH - 1081430

Technical data

Connection data, input

Conductor cross section solid max.	2.5 mm ²
Conductor cross section flexible min.	0.2 mm ²
Conductor cross section flexible max.	2.5 mm ²
Conductor cross section AWG min.	24
Conductor cross section AWG max.	12
Stripping length	6.5 mm
Screw thread	M3

Connection data, output

Connection method	Screw connection
Conductor cross section solid min.	0.2 mm ²
Conductor cross section solid max.	2.5 mm ²
Conductor cross section flexible min.	0.2 mm ²
Conductor cross section flexible max.	2.5 mm ²
Conductor cross section AWG min.	24
Conductor cross section AWG max.	12
Stripping length	6.5 mm
Screw thread	M3

Connection data for signaling

Conductor cross section solid min.	0.2 mm ²
Conductor cross section solid max.	2.5 mm ²
Conductor cross section flexible min.	0.2 mm ²
Conductor cross section flexible max.	2.5 mm ²
Conductor cross section AWG min.	24
Conductor cross section AWG max.	12
Stripping length	6.5 mm
Screw thread	M3

Charging process

Quality check of battery	Yes, every time it is charged and cyclically once a month
Deep discharge protection	< 15 V DC

Standards

EMC requirements for noise immunity	EN 61000-6-2
Standard - Electrical safety	EN 60950-1/VDE 0805 (SELV)
Standard – Electronic equipment for use in electrical power installations and their assembly into electrical power installations	EN 50178/VDE 0160 (PELV)

Conformance/approvals

UL approvals	UL Listed UL 508
	UL/C-UL Recognized UL 60950-1

Uninterruptible power supply - STEP-UPS/24DC/24DC/3/46WH - 1081430

Technical data

EMC data

Electromagnetic compatibility	Conformance with EMC Directive 2014/30/EU
Electrostatic discharge	EN 61000-4-2
Contact discharge	6 kV (Test Level 3)
Discharge in air	8 kV (Test Level 3)
Electromagnetic HF field	EN 61000-4-3
Frequency range	80 MHz ... 1 GHz
Test field strength	10 V/m (Test Level 3)
Frequency range	1 GHz ... 2 GHz
Test field strength	10 V/m (Test Level 3)
Frequency range	2 GHz ... 3 GHz
Test field strength	10 V/m (Test Level 3)
Comments	Criterion A
Fast transients (burst)	EN 61000-4-4
Input	2 kV (Test Level 3 - asymmetrical)
Output	2 kV (Test Level 3 - asymmetrical)
Signal	2 kV (Test Level 4 - asymmetrical)
Comments	Criterion A
Surge voltage load (surge)	EN 61000-4-5
Input	1 kV (Test Level 2 - symmetrical)
	2 kV (Test Level 3 - asymmetrical)
Output	1 kV (Test Level 2 - symmetrical)
	2 kV (Test Level 3 - asymmetrical)
Signal	1 kV (Test Level 2 - asymmetrical)
Comments	Criterion A
Conducted interference	EN 61000-4-6
I/O/S	asymmetrical
Frequency range	0.15 MHz ... 80 MHz
Voltage	10 V (Test Level 3)
Comments	Criterion A
Criterion A	Normal operating behavior within the specified limits.
Criterion B	Temporary impairment to operational behavior that is corrected by the device itself.

Environmental Product Compliance

REACH SVHC	Lead 7439-92-1
------------	----------------

Drawings

Uninterruptible power supply - STEP-UPS/24DC/24DC/3/46WH - 1081430

Block diagram

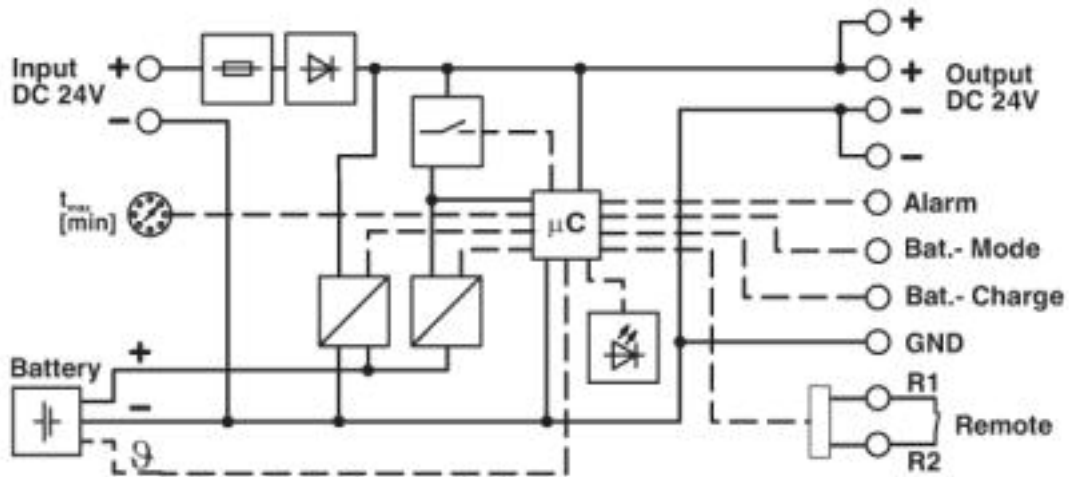

Classifications

eCl@ss

eCl@ss 9.0	27040705
------------	----------

ETIM

ETIM 6.0	EC000382
ETIM 7.0	EC000382

Accessories

Accessories

Battery unit

Battery - STEP-BAT/LI-ION/18.5DC/46WH - 1081355



Replacement battery module, lithium-ion, 18.5 V DC, 46 Wh

Power supply

Power supply unit - STEP-PS/ 1AC/24DC/4.2 - 2868664



Primary-switched STEP POWER power supply for DIN rail mounting, input: 1-phase, output: 24 V DC/4.2 A

Uninterruptible power supply - STEP-UPS/24DC/24DC/3/46WH - 1081430

Accessories

Phoenix Contact 2020 © - all rights reserved
<http://www.phoenixcontact.com>