

SIPLUS SIMOCODE pro V Basic unit 2 -25...+60°C with conformal coating based on 3UF7010-1AU00-0 . E- type with "Safety ""12 Mbit/s, RS485;"" "4I/3O freely parameterizable;" "US: 110-240V AC/DC; input for "thermistor connection;" "monostable relay outputs;" expandable by extension modules



Figure similar

Product brand name	SIPLUS
Product designation	Motor management system
Design of the product	basic unit 2
Product type designation	SIMOCODE pro V

General technical data	
Product function	
• Bus communication	Yes
• data acquisition function	Yes
• Diagnostics function	Yes
• Password protection	Yes
• Test function	Yes
• maintenance function	Yes
Product component	
• input for thermistor connection	Yes
• Digital input	Yes
• input for analog temperature sensors	No
• input for ground fault detection	No

• Relay output	Yes
Product extension	
• Temperature monitoring module	Yes
• Current measuring module	Yes
• Current/voltage measuring module	Yes
• failsafe digital I/O module	Yes
• Ground fault monitoring module	Yes
• Control unit with display	Yes
• Control unit	Yes
• analog I/O module	Yes
Insulation voltage	
• with degree of pollution 3 at AC rated value	300 V
Surge voltage resistance rated value	4 000 V
Protection class IP	IP20
Shock resistance	
• acc. to IEC 60068-2-27	15g / 11 ms
Vibration resistance	1-6 Hz / 15 mm; 6-500 Hz / 2 g
Switching capacity current of the NO contacts of the relay outputs at AC-15	
• at 24 V	6 A
• at 120 V	6 A
• at 230 V	3 A
Switching capacity current of the NO contacts of the relay outputs at DC-13	
• at 24 V	2 A
• at 60 V	0.55 A
• at 125 V	0.25 A
Mechanical service life (switching cycles)	
• typical	10 000 000
Electrical endurance (switching cycles)	
• typical	100 000
Buffering time in the event of power failure	0.2 s
Reference code acc. to DIN EN 81346-2	F
Continuous current of the NO contacts of the relay outputs	
• at 50 °C	6 A
• at 60 °C	5 A
Type of input characteristic	Type 1 in accordance with EN 61131-2
Electromagnetic compatibility	
EMC emitted interference	
• acc. to IEC 60947-1	class A
EMI immunity acc. to IEC 60947-1	corresponds to degree of severity 3

Conducted interference	
<ul style="list-style-type: none"> • due to burst acc. to IEC 61000-4-4 	2 kV (power ports) / 1 kV (signal ports)
<ul style="list-style-type: none"> • due to conductor-earth surge acc. to IEC 61000-4-5 	2 kV
<ul style="list-style-type: none"> • due to conductor-conductor surge acc. to IEC 61000-4-5 	1 kV
<ul style="list-style-type: none"> • due to high-frequency radiation acc. to IEC 61000-4-6 	10 V
Field-bound parasitic coupling acc. to IEC 61000-4-3	10 V/m
Electrostatic discharge acc. to IEC 61000-4-2	6 kV contact discharge / 8 kV air discharge
Conducted HF-interference emissions acc. to CISPR11	corresponds to degree of severity A
Field-bound HF-interference emission acc. to CISPR11	corresponds to degree of severity A

Inputs/ Outputs

Product function	
<ul style="list-style-type: none"> • Parameterizable inputs 	Yes
<ul style="list-style-type: none"> • Parameterizable outputs 	Yes
Number of inputs	4
<ul style="list-style-type: none"> • for thermistor connection 	1
Number of digital inputs	
<ul style="list-style-type: none"> • with a common reference potential 	4
Digital input version	
<ul style="list-style-type: none"> • Type 1 acc. to IEC 61131 	Yes
Input voltage at digital input at DC rated value	24 V
Number of outputs	3
Number of semiconductor outputs	0
Number of outputs as contact-affected switching element	3
Switching behavior	monostable
Wire length for digital signals maximum	300 m
Wire length for thermistor connection	
<ul style="list-style-type: none"> • with conductor cross-section = 0.5 mm² maximum 	50 m
<ul style="list-style-type: none"> • with conductor cross-section = 1.5 mm² maximum 	150 m
<ul style="list-style-type: none"> • with conductor cross-section = 2.5 mm² maximum 	250 m

Protective and monitoring functions

Product function	
<ul style="list-style-type: none"> • Phase unbalance 	Yes
<ul style="list-style-type: none"> • blocking current evaluation 	Yes
<ul style="list-style-type: none"> • power factor monitoring 	Yes

• Ground fault detection	Yes
• Phase failure detection	Yes
• phase sequence recognition	Yes
• voltage detection	Yes
• Monitoring of number of start operations	Yes
• Overvoltage detection	Yes
• Overcurrent detection 1 phase	Yes
• undervoltage detection	Yes
• undercurrent detection 1 phase	Yes
• active power monitoring	Yes
Product function	
• Current detection	Yes
• Overload protection	Yes
• Evaluation of thermistor motor protection	Yes
Response value of thermoresistor	3 400 ... 3 800 Ω
Release value of thermoresistor	1 500 ... 1 650 Ω

Motor control functions

Product function	
• parameterizable overload relay	Yes
• circuit breaker control	Yes
• direct start	Yes
• reverse starting	Yes
• star-delta circuit	Yes
• star-delta reversing circuit	Yes
• Dahlander circuit	Yes
• Dahlander reversing circuit	Yes
• pole-changing switch circuit	Yes
• pole-changing switch reversing circuit	Yes
• Slide control	Yes
• valve control	Yes

Communication/ Protocol

• Protocol is supported PROFIBUS DP protocol	Yes
• Protocol is supported PROFINET IO protocol	No
• Protocol is supported PROFI-safe protocol	Yes
• Protocol is supported Modbus RTU	No
• Protocol is supported EtherNet/IP	No
• Protocol is supported OPC UA Server	No
• Protocol is supported LLDP	No
• Protocol is supported Address Resolution Protocol (ARP)	No
• Protocol is supported SNMP	No

<ul style="list-style-type: none"> • Protocol is supported HTTPS 	No
<ul style="list-style-type: none"> • Protocol is supported NTP 	No
<ul style="list-style-type: none"> • Protocol is supported Media Redundancy Protocol (MRP) 	No
<ul style="list-style-type: none"> • Product function is supported Device Level Ring (DLR) 	No
Number of interfaces	
<ul style="list-style-type: none"> • acc. to PROFIBUS 	1
Product function	
<ul style="list-style-type: none"> • web server 	No
<ul style="list-style-type: none"> • shared device 	No
<ul style="list-style-type: none"> • at the Ethernet interface Autocrossover 	No
<ul style="list-style-type: none"> • at the Ethernet interface Autonegotiation 	No
<ul style="list-style-type: none"> • at the Ethernet interface Autosensing 	No
<ul style="list-style-type: none"> • is supported PROFINET system redundancy 	No
<ul style="list-style-type: none"> • supports PROFINET energy measured values 	No
<ul style="list-style-type: none"> • supports PROFINET energy shutdown 	No
Transfer rate maximum	12 Mbit/s
Identification & maintenance function	
<ul style="list-style-type: none"> • I&M0 - device-specific information 	Yes
<ul style="list-style-type: none"> • I&M1 – higher-level designation/location designation 	Yes
<ul style="list-style-type: none"> • I&M2 - installation date 	Yes
<ul style="list-style-type: none"> • I&M3 - comment 	Yes
Type of electrical connection	
<ul style="list-style-type: none"> • of the communication interface 	9-pin SUB-D socket (12 Mbit) / screw terminal (1.5 Mbit)

Installation/ mounting/ dimensions	
Mounting position	any
Mounting type	screw and snap-on mounting
Height	111 mm
Width	45 mm
Depth	124 mm

Connections/ Terminals	
Product function	
<ul style="list-style-type: none"> • removable terminal for auxiliary and control circuit 	Yes
Type of electrical connection	
<ul style="list-style-type: none"> • for auxiliary and control current circuit 	screw-type terminals
Type of connectable conductor cross-sections	
<ul style="list-style-type: none"> • solid 	1x (0.5 ... 4.0 mm ²), 2x (0.5 ... 2.5 mm ²)
<ul style="list-style-type: none"> • finely stranded with core end processing 	1x (0.5 ... 2.5 mm ²), 2x (0.5 ... 1.5 mm ²)
<ul style="list-style-type: none"> • at AWG conductors solid 	1x (20 ... 12), 2x (20 ... 14)

<ul style="list-style-type: none"> • at AWG conductors stranded 	1x (20 ... 14), 2x (20 ... 16)
Tightening torque <ul style="list-style-type: none"> • with screw-type terminals 	0.8 ... 1.2 N·m
Tightening torque [lbf·in] <ul style="list-style-type: none"> • with screw-type terminals 	7 ... 10.3 lbf·in
Type of connectable conductor cross-sections for PROFIBUS wire	2x 0.34 mm ² , AWG 22

Ambient conditions

Installation altitude at height above sea level <ul style="list-style-type: none"> • 1 maximum • 2 maximum • 3 maximum 	2 000 m 3 000 m 4 000 m; max. +40 °C (no protective separation)
Ambient temperature <ul style="list-style-type: none"> • during operation 	-25 ... +60 °C
Relative humidity <ul style="list-style-type: none"> • with condensation maximum 	100 %; RH incl. condensation/frost (no commissioning in bedewed state)
Ambient condition relating to ambient temperature - air pressure - installation altitude	-25 ... +60°C at 1080 hPa ... 795 hPa (-1000 m ... +2000 m) // -25 ... +50°C at 795 hPa ... 658 hPa (+2000 m ... +3500 m) // -25 ... +40°C at 658 hPa ... 540 hPa (+3500 m ... +5000 m)
Resistance to mechanically active substances conformity acc. to EN 60721-3-3	Yes; Compliant with EN 60721-3-3, Class 3S4 incl. sand, dust; the supplied plug covers must remain in place on the unused interfaces during operation.
Resistance to chemically active substances conformity acc. to EN 60721-3-3	Yes; Compliant with EN 60721-3-3, Class 3B2 mold and fungal spores (except fauna); the supplied plug covers must remain in place on the unused interfaces during operation.
Resistance to biologically active substances conformity acc. to EN 60721-3-3	Yes; Compliant with EN 60721-3-3, Class 3C4 incl. salt spray in accordance with EN 60068-2-52 (severity 3); the supplied plug covers must remain in place on the unused interfaces during operation.
Resistance to salt-laden atmosphere conformity acc. to EN 60068-2-52	Yes; Severity 3
Contact rating of auxiliary contacts according to UL	B300 / R300

Short-circuit protection

Design of short-circuit protection <ul style="list-style-type: none"> • per output 	Fuse links: gG 6 A, quick-response 10 A (IEC 60947-5-1), miniature circuit-breaker C char.: 1.6 A (IEC 60947-5-1) or 6 A (I_K < 500 A)
--	--

Safety related data

Protection against electrical shock	finger-safe
--	-------------

Main circuit

Operating voltage <ul style="list-style-type: none"> • at AC 	
--	--

— at 50 Hz rated value	110 ... 240 V
— at 60 Hz rated value	110 ... 240 V
• at DC	
— rated value	110 ... 240 V

Control circuit/ Control

Product function soft starter control	Yes
Type of voltage of the control supply voltage	AC/DC
Control supply voltage at AC	
• at 50 Hz rated value	110 ... 240 V
• at 60 Hz rated value	110 ... 240 V
Control supply voltage frequency	
• 1 rated value	50 Hz
• 2 rated value	60 Hz
Control supply voltage at DC	
• rated value	110 ... 240 V
Control supply voltage 1	
• at DC rated value	240 V
Operating range factor control supply voltage rated value at DC	
• initial value	0.85
• Full-scale value	1.1
Operating range factor control supply voltage rated value at AC at 50 Hz	
• initial value	0.85
• Full-scale value	1.1
Operating range factor control supply voltage rated value at AC at 60 Hz	
• initial value	0.85
• Full-scale value	1.1

Certificates/ approvals

Further information

Information- and Downloadcenter (Catalogs, Brochures,...)

www.siemens.com/ic10

Industry Mall (Online ordering system)

<https://mall.industry.siemens.com/mall/en/en/Catalog/product?mlfb=6AG1010-1AU00-4AA0>

Cax online generator

<http://support.automation.siemens.com/WW/CAXorder/default.aspx?lang=en&mlfb=6AG1010-1AU00-4AA0>

Service&Support (Manuals, Certificates, Characteristics, FAQs,...)

<https://support.industry.siemens.com/cs/ww/en/ps/6AG1010-1AU00-4AA0>

Image database (product images, 2D dimension drawings, 3D models, device circuit diagrams, EPLAN macros, ...)

http://www.automation.siemens.com/bilddb/cax_de.aspx?mlfb=6AG1010-1AU00-4AA0&lang=en

Test report No. A0258, protective separation

<https://support.industry.siemens.com/cs/ww/en/view/109748152>

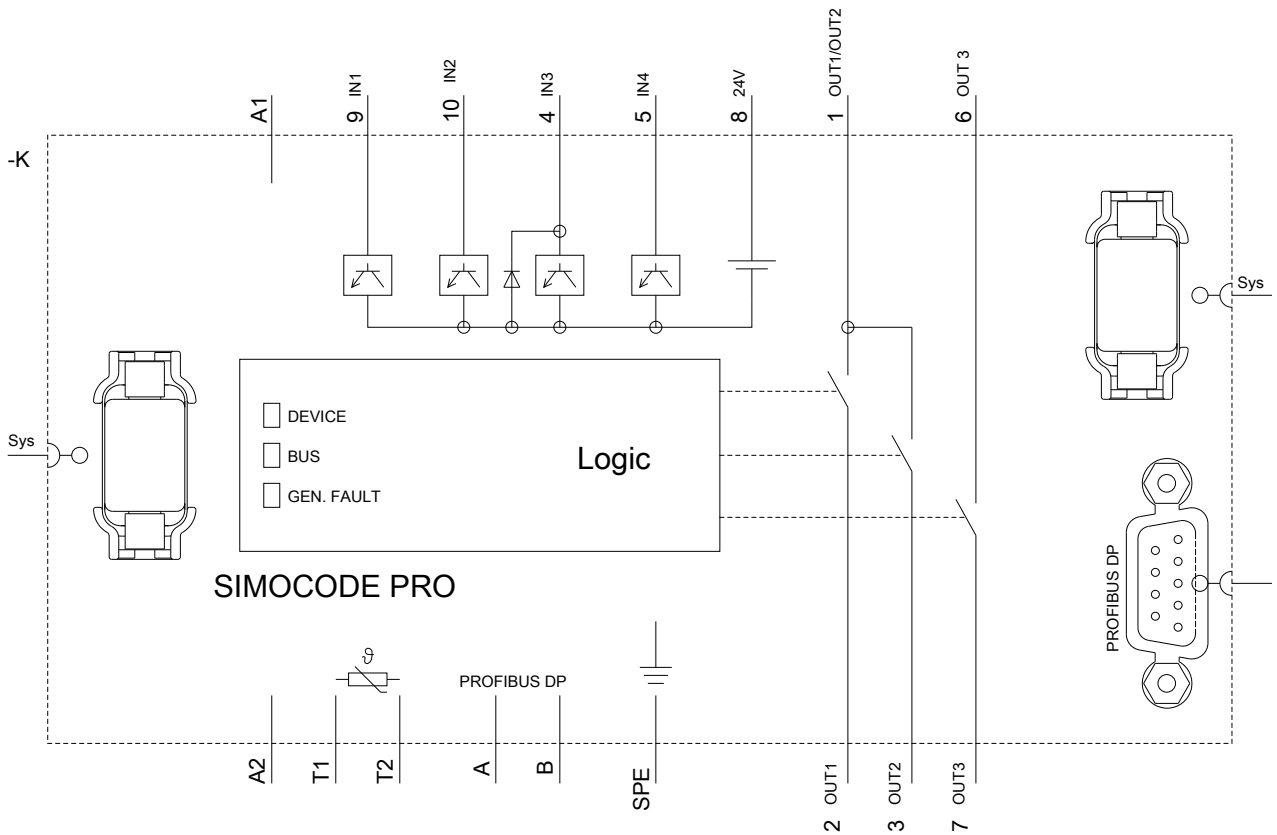

last modified:

03/26/2020